

**4096-668**

**June 1 2016**

**ASSEMBLY MANUAL**

**Revision C**

# **Assembly Instruction for Series 3180 1.8M Ka-Band Antenna**

**General Dynamics SATCOM Technologies**

**1700 Cable Drive NE**

**CONOVER NC 28613 USA**

**Phone 770-689-2040**

**[www.gdsatcom.com](http://www.gdsatcom.com)**

**1.8M Ka-BAND Rx/Tx  
SERIES 3180 ANTENNA SYSTEM**

C	Add Conover Address	6/1/16	RAH
B	Revised and updated.	03/22/12	R.F.
A	Revised Company Name and Logo	6/1/09	RAH
-	ORIGINAL RELEASE	8/25/04	
<b>REV.</b>	<b>DESCRIPTION</b>	<b>DATE</b>	<b>APPROVED</b>

**TABLE OF CONTENTS**

<b><u>SECTION</u></b>	<b><u>TITLE</u></b>
<b>I</b>	<b>GENERAL INFORMATION</b>
1.0	Introduction
1.1	Unpacking And Inspection
1.2	Freight Damage
1.3	Missing Or Damaged Material
1.4	Suggested Tool List
1.5	Mechanical Alignment Tools
1.6	Site Selection
1.7	Suggested Mast & Foundation
<b>II</b>	<b>ANTENNA SYSTEM</b>
2.0	Antenna Assembly
<b>III</b>	<b>FEED AND FEED SUPPORT</b>
3.0	Feed And Feed Support Assembly
<b>IV</b>	<b>ANTENNA POINTING</b>
4.0	Alignment To Satellite
4.1	Initial Alignment
4.2	Fine Tuning
<b>V</b>	<b>MAINTENANCE</b>
5.0	Maintenance Overview
5.1	Periodic Inspection
5.2	Reflector
5.3	Mount And Reflector Support
5.4	Feed System



**SECTION I**                      **GENERAL INFORMATION****1.0**        **INTRODUCTION**

This manual describes the assembly and installation of General Dynamics' 1.8M antenna system with Az/El mount. The General Dynamics 1.8M is a rugged, reliable antenna system, which will operate with high efficiency and at the same time successfully withstand the effects of the environment. The basic 1.8M antenna consists of an offset reflector, reflector support, feed support structure and Az/El positioner.

These instructions are listed by sections that cover all areas of assembly and installation. Additional sections are included in the manual to provide information on antenna alignment to the satellite and maintenance.

**1.1**        **UNPACKING AND INSPECTION**

The antenna containers should be unpacked and inspected at the earliest date to ensure that all material has been received and is in good condition.

**1.2**        **FRIEGHT DAMAGE**

Any damage to materials while in transit should be immediately directed to the freight carrier. He will instruct you on matters regarding any freight damage claims.

**1.3**        **MATERIAL - MISSING OR DAMAGED**

Any questions regarding missing or damaged materials that is not due to the freight carrier should be directed to General Dynamics' Customer Service Department at:

**General Dynamics SATCOM Technologies**

**1700 Cable Drive NE**

**CONOVER NC 28613 USA**

**Phone 770-689-2040**

**[www.gdsatcom.com](http://www.gdsatcom.com)**

**1.4 SUGGESTED TOOL LIST**

The following tools are suggested for the antenna installation.

<b>HARDWARE SIZE</b>	<b>SAE WRENCH SIZE</b>	<b>METRIC WRENCH SIZE</b>	<b>MAXIMUM REC. TORQUE</b>
<b>1/4" BOLT</b>	<b>7/16"</b>	<b>11mm</b>	<b>6.5 ft-lbs</b>
<b>5/16" BOLT</b>	<b>1/2"</b>	<b>13 mm</b>	<b>12 ft-lbs</b>
<b>1/2" BOLT</b>	<b>3/4"</b>	<b>20 mm</b>	<b>45 ft-lbs</b>
<b>3/4" BOLT</b>	<b>1-1/8"</b>	<b>29 mm</b>	<b>145 ft-lbs</b>

**NOTE: The Minimum Torque applied should not be less than 10% of maximum recommended torque.**

**1.5 MECHANICAL ALIGNMENT TOOLS**

The following tools are suggested for the initial alignment to the satellite.

- 1) COMPASS
- 2) INCLINOMETER
- 3) 10" CRESCENT WRENCH
- 4) SCREWDRIVER, STANDARD BLADE

**1.6 SITE SELECTION**

In order to achieve maximum performance of your antenna system, it is important to select the correct location for the antenna. The following guidelines should be observed when selecting a site for the installation.

1. The line of site to the satellite should be clear of any obstructions, such as trees or buildings.
2. The site should be relatively flat and level for ease of installation and access to the antenna.
3. The site should be checked for underground obstruction, such as buried cables or pipes.
4. All local building codes should be adhered to (i.e. grounding, foundation requirements, zoning rules, setbacks, etc.).

**1.7 SUGGESTED MAST & FOUNDATION**

The required interface from the foundation to the mount is 5" schedule 80 pipe (5.56" O.D.). A suggested in-ground foundation is shown in Figure 1.

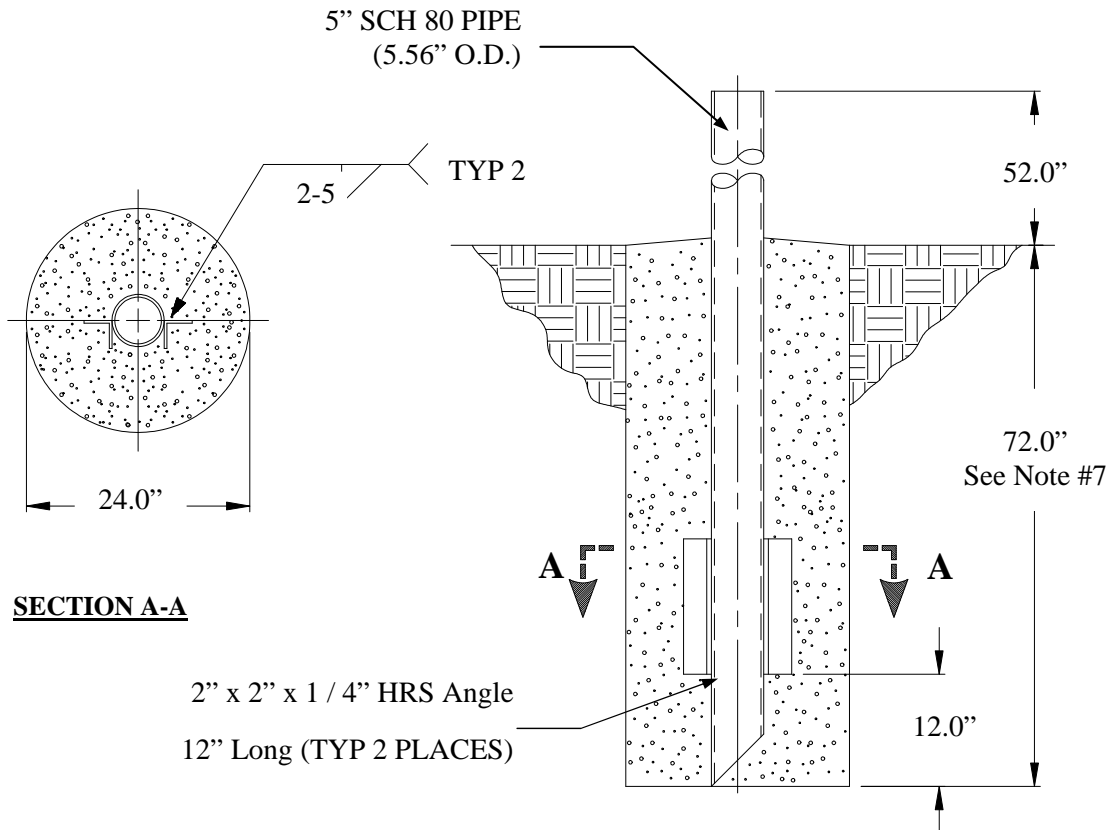
**FIGURE 1.****NOTES:**

1. 2 x 2 x 1/4 HRS Angle and schedule 80 pipe should conform with ASTM A36 structural steel.
2. All concrete should conform to building code standards and have a minimum compressive strength of 3000 PSI at 28 days. (Per ACI-318-77)
3. Soil bearing capacity should be no less than 2000 PSF.
4. Concrete should be poured against undisturbed soil.
5. Allow concrete 24 hours set time before installation of antenna.
6. The antenna should be properly grounded to meet applicable local codes.
7. Minimum depth as shown or extend to local frost line.

**(GENERAL DYNAMICS DOES NOT REPRESENT OR WARRANT THAT ANY PARTICULAR DESIGN OR SIZE OF FOUNDATION IS APPROPRIATE FOR ANY LOCALITY OR EARTH STATION INSTALLATION.)**

**SECTION II**      **ANTENNA ASSEMBLY**

<b>PARTS LIST - 1.8M ANTENNA PARTS LIST</b>			
<b>ITEM</b>	<b>PART NO.</b>	<b>DESCRIPTION</b>	<b>QTY</b>
1	VARIES	1.8M REFLECTOR	1
2	0490-814	REFLECTOR SUPPORT	1
3	0185-358	ASSEMBLY, 1.8M Az/EI	1
4	0185-357	ASSEMBLY, 1.8M ELEVATION ADJ. ROD	1
5	0211-918	BRACKET, TAILPIECE SUPPORT	1
6	0162-193	SLEEVE, ELEVATION PIVOT	1
7	8043-048	BOLT, ½-13 X 6.00 CARRIAGE	4
8	8033-014	BOLT, ½-13 X 1.75 HEX	1
9	8201-030	½" FLATWASHER	6
10	8202-043	½" LOCKWASER	5
11	8104-007	½" HEX NUT	5
12	8035-012	BOLT, ¾-10 X 1.50 HEX	2
13	8035-016	BOLT, ¾-10 X 2.00 HEX	2
14	8201-047	¾" FLATWASHER	4
15	8202-045	¾" LOCKWASER	4
16	8031-044	BOLT, 5/16-18 X 5.50 HEX	2
17	8201-041	5/16" FLATWASHER	4
18	8202-041	5/16" LOCKWASER	2
19	8101-009	NUT, 5/16 HEX	2

**CAUTION: During the assembly procedure, the sequence of instructions must be followed. DO NOT TIGHTEN ANY HARDWARE UNTIL INSTRUCTED.**



## 2.0 ANTENNA ASSEMBLY

Follow the steps below in the order shown to assemble the antenna. Because of the weight and size of some of the antenna components, a minimum two person crew is recommended. Do not tighten any hardware until instructed to do so.

### Installing the AZ/EL assembly onto the mast pipe

1. Use a ½-inch open-end wrench to loosen the eight canister set screws until they are flush with the inside wall of the canister.
2. Lift the AZ/EL assembly (Item #3) and slide the canister over the top of the mast pipe.
3. Rotate the AZ/EL assembly until the reflector side is oriented in the general direction of the satellite as shown.
4. Snug the eight canister set screws enough to prevent the assembly from rotating. Do not tighten until instructed to do so later in the assembly.

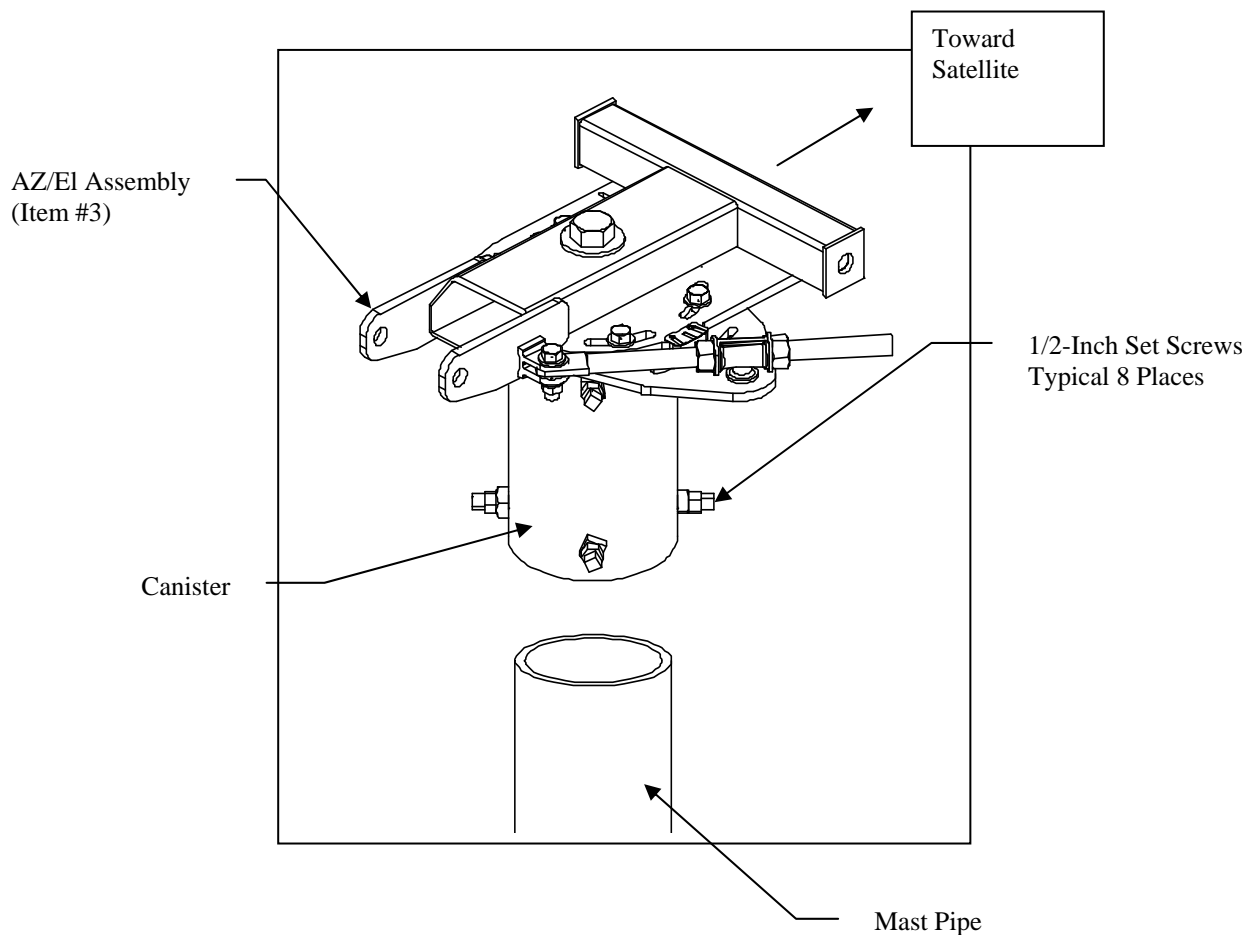

**Installing the reflector support**

1. Lift the reflector support (Item #2) and position the two mounting plates onto the AZ/EL assembly. Look for the elevation mounting bracket and ensure that it is rotated to the top of the reflector support.
2. Install a  $\frac{3}{4}$ -10 x 2.00-Inch bolt with flat washer and lock washer (Items #13, 14, 15) on each side of the reflector support.

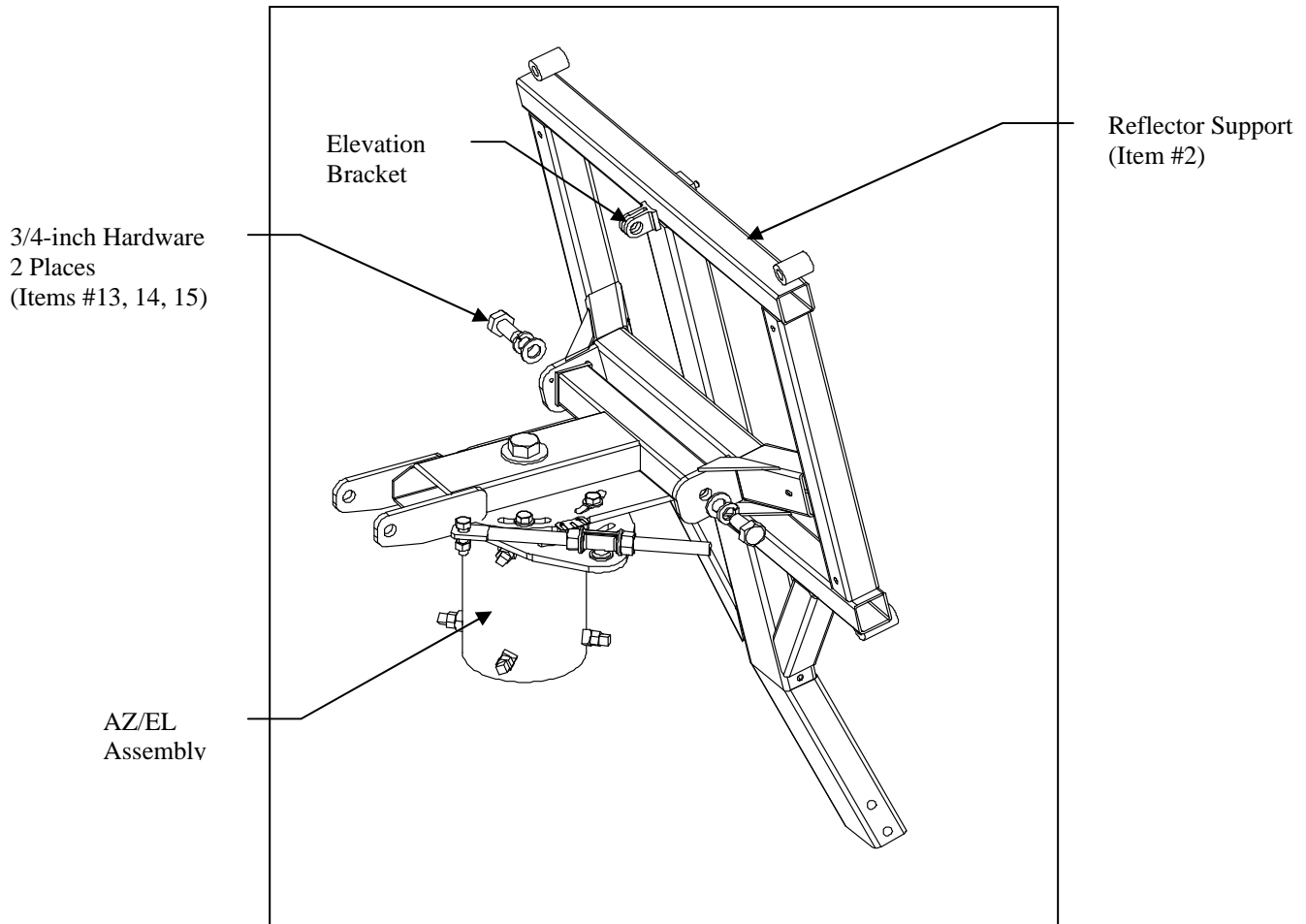

3. Attach the elevation adjustment rod (Item #4) to the elevation mounting bracket of the reflector support with the elevation pivot sleeve,  $\frac{1}{2}$ -13 x 1.75-inch bolt, two flat washers, and hex nut (Items #6, 8, 9, 10, 11).
4. Raise the reflector support until the elevation adjustment block is aligned between the mounting plates at the back of the AZ/EI assembly.
5. Install a  $\frac{3}{4}$ -10 x 1.50-inch bolt, flat washer, and lock washer (Items #12, 14, 15) from each side of the assembly.

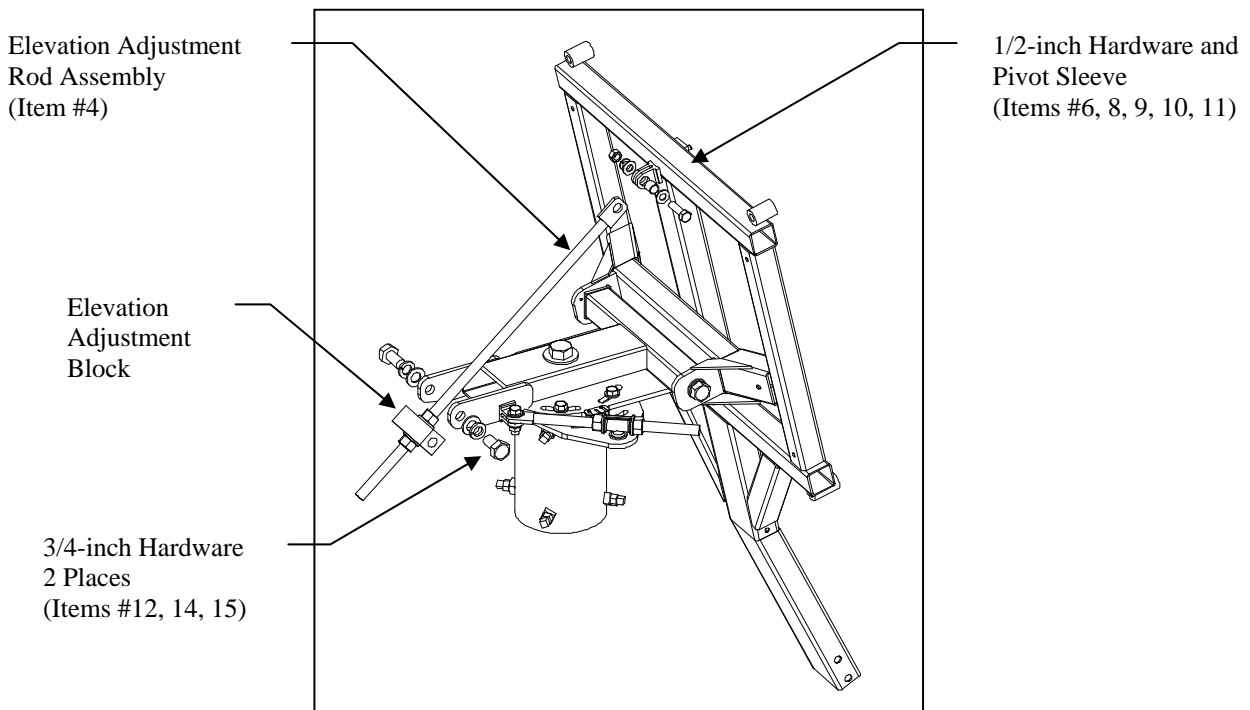

6. Attach the tailpiece support bracket (Item #5) to the reflector support by using (2) 5/16 x 5.50-inch bolts, (4) 5/16-inch flat washers, (2) 5/16-inch lock washers and (2) 5/16-inch hex nuts (Items #16, 17, 18, 19).
7. Snug but do not tighten the two 5/16-inch bolts that attach the tailpiece support bracket to the reflector support until after feed support installation (Section III).

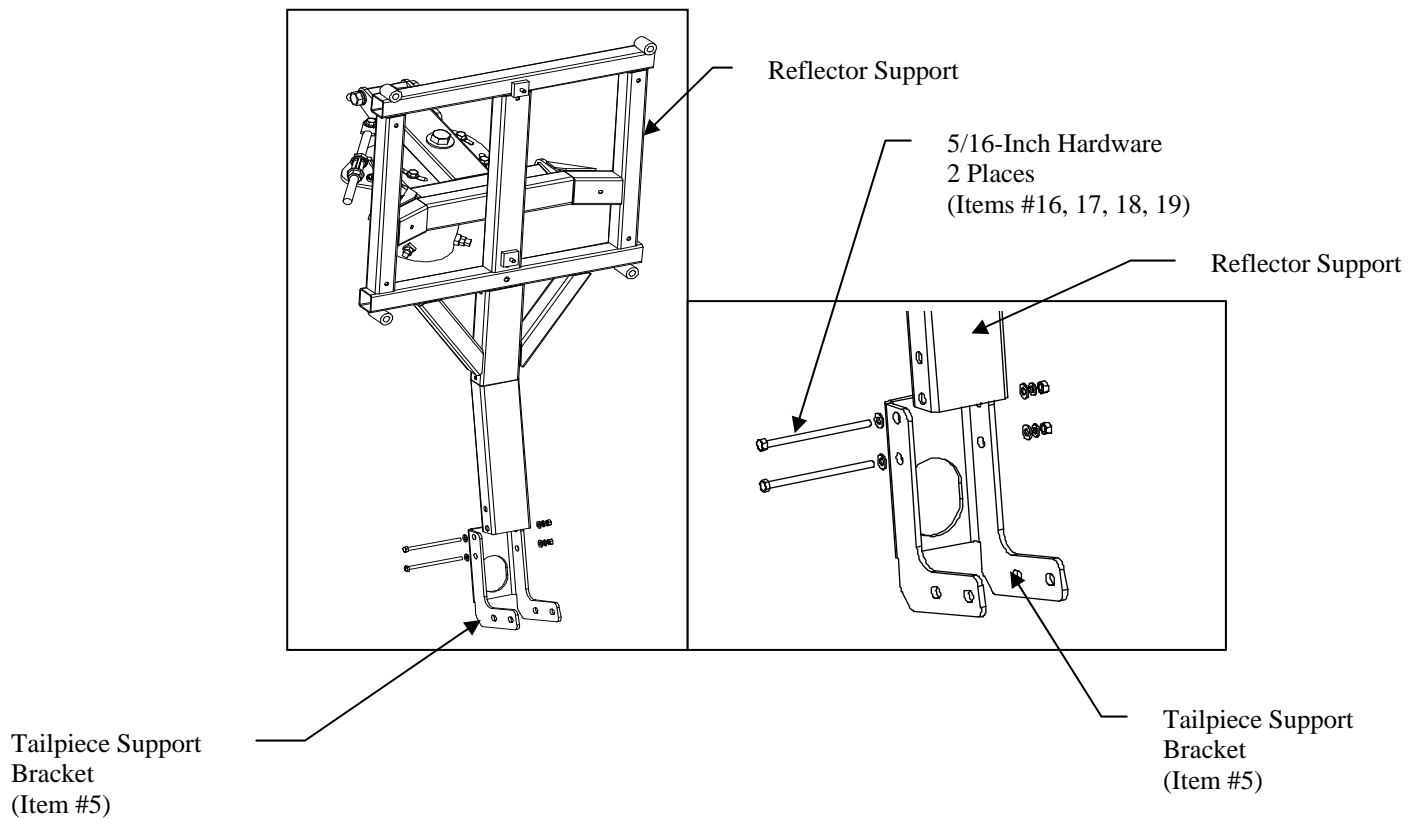

**Attaching the reflector**

1. Orient the reflector (Item #1) so that the feed support pocket is at the bottom.
2. Lift the reflector and position onto the reflector support.
3. Attach by inserting a 1/2-13 x 6.00-inch carriage bolt (Item #7) through each of the four holes in the reflector from the front to the back and through the mounting holes of the reflector support.
4. Secure with a flat washer, lock washer, and hex nut (Items #9, 10, 11) on each of the four carriage bolts.
5. Tighten securely.

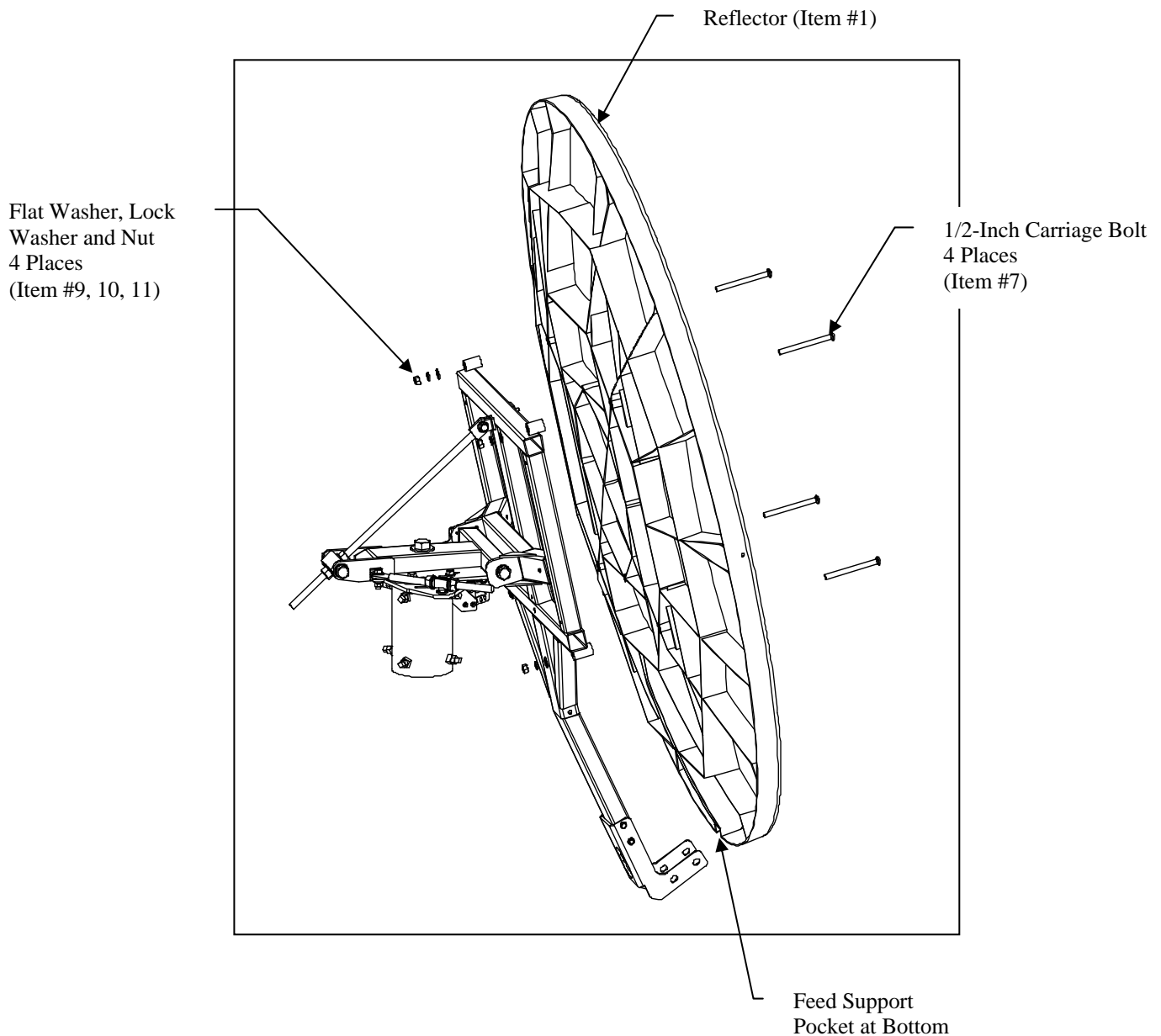

**SECTION III**                      **FEED AND FEED SUPPORT ASSEMBLY**

These instructions are intended as a general reference for feed and feed support assembly. If your antenna system has specific feed or feed support installation instructions, please refer to them at this time.

<b>PARTS LIST - 1.8M FEED SYSTEM PARTS LIST</b>			
<b>ITEM</b>	<b>PART NO.</b>	<b>DESCRIPTION</b>	<b>QTY</b>
1	VARIES	ASSEMBLY, KA-BAND FEED	1
2	VARIES	FEED SUPPORT	1
3	0176-304	FEED ROD	2
4	8031-044	BOLT, 5/16-18 X 5.50 HEX	2
5	8031-008	BOLT, 5/16-18 X 1.00 HEX	5
6	8031-024	BOLT, 5/16-18 X 3.25 HEX	1
7	8201-041	5/16" FLATWASHER	16
8	8202-041	5/16" LOCKWASER	8
9	8101-009	5/16" HEX NUT	8

**Attaching the feed support**

1. Place the feed support (Item #2) between the mounting ears of the tailpiece and into the pocket at the bottom of the reflector.
2. Insert a 5/16-18 x 1.00-inch bolt and flat washer (Items #5, 7) through the hole in the feed support and the hole in the top of the pocket of the reflector and secure with a flat washer, lock washer and hex nut (Items #7, 8, 9) on the back of the reflector. Do not tighten.
3. With the feed support attached to the reflector, install a 5/16-18 x 5.50-inch bolt and flat washer (Item #4, 7) through the two holes in the tailpiece and feed support and secure with a flat washer, lock washer and hex nut (Items #7, 8, 9) on each bolt. Do not tighten.

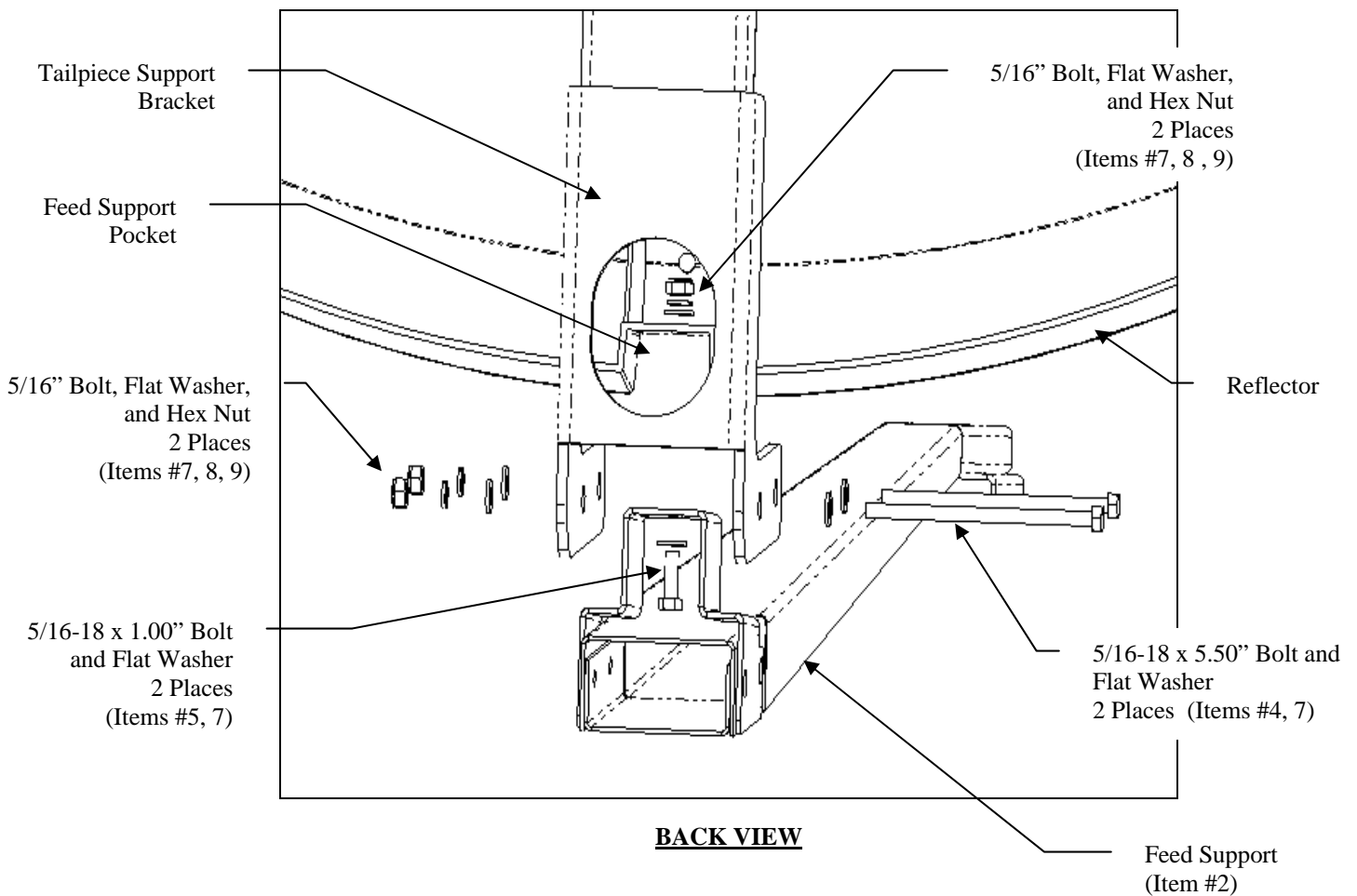

- Attach a feed rod to the mounting hole in the side of the reflector with a 5/16-18 x 1.00-inch bolt and flat washer (Items #5, 7) and secure with a flat washer, lock washer, and hex nut (Items #7, 8, 9) on the back side of the reflector.

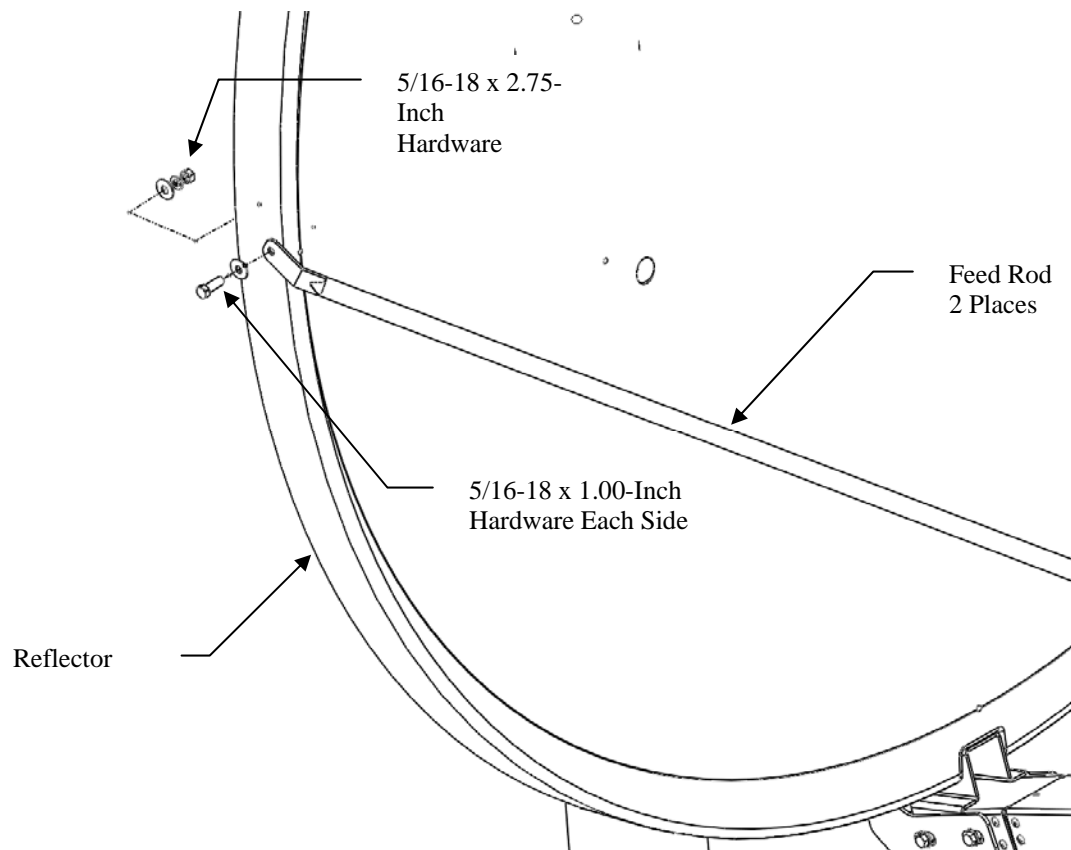

- Repeat with the remaining feed rod on the opposite side of the reflector.
- Raise the two feed rods and attach to the feed support with a 5/16-18 x 3.25-inch bolt and flat washer (Items #6, 7) through one feed rod, through the hole in the feed support and through the other feed rod and secure with flat washer, lock washer and hex nut (Items #7, 8, 9).

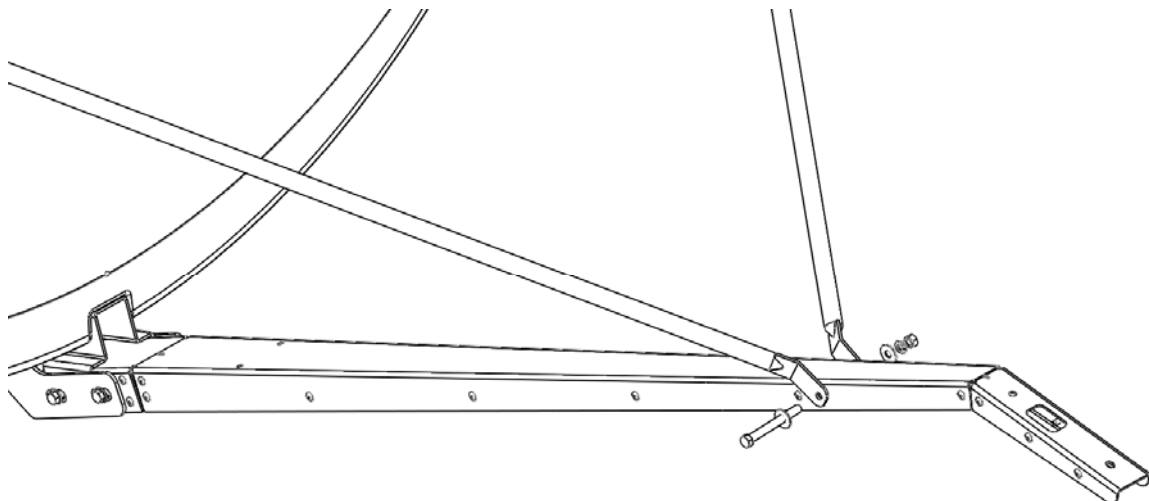



7. Tighten securely the three 5/16-inch bolts used to attach the feed system to the reflector and the 5/16-inch bolt used to attach the feed rods to the feed support at this time.
8. Tighten securely the two 5/16" bolts attaching the tailpiece to the feed support and the two 5/16" bolts attaching the tailpiece to the reflector support at this time.

### Attaching the feed assembly

1. Attach feed assembly with its' mounting bracket to the end of the feed support with a 5/16 x 1.00" bolt and flat washer (Items #5, 7) in each of the mounting bracket holes aligning them with the two holes in the end of the feed support.
2. Secure with a flat washer, lock washer, and hex nut (Items #7, 8, 9) on the bottom of the feed support. Tighten securely.
3. **Note:** Depending on the configuration of your feed assembly, it may vary in physical appearance from the illustration below. The mounting bracket will correctly position the feed on the feed support using the two mounting holes.

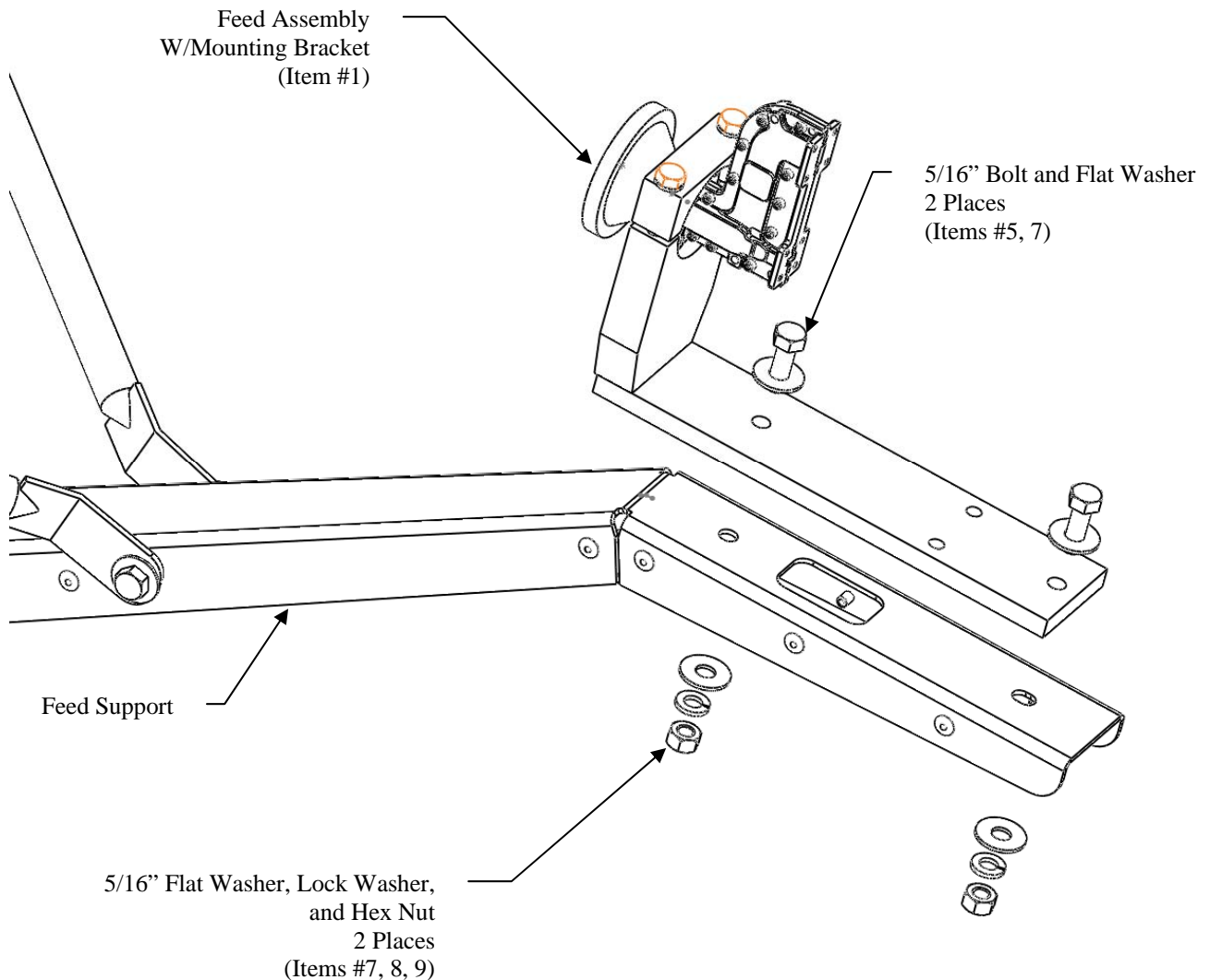

## **SECTION IV**      **ANTENNA POINTING**

### **4.0 Alignment To Satellite**

General Dynamics' 1.8 meter Az/El mount requires that the antenna be aligned to the satellite orbital arc initially by a trained installer.

### **4.1 Initial Alignment**

The 1.8 meter offset reflector contains a  $17.35^\circ$  elevation offset look angle. Therefore, when the reflector aperture is perpendicular to the ground, the antenna is actually looking  $17.35^\circ$  in elevation.

- 1) Aligning to satellite: Attach an inclinometer to the reflector support structure as shown in figure 4.1. Add  $17.35^\circ$  to the reading on the inclinometer to accommodate the reflector's offset angle.
- 2) Raise or lower the antenna to find the desired elevation by turning the 3/4" nuts located at the elevation block. Position the top nut so that it will not interfere with adjustment. Turn the bottom nut clockwise to increase elevation and counter clockwise to decrease elevation.
- 3) After the correct elevation angle is set, rotate the antenna in azimuth by loosening the canister and turning the entire assembly on the mast pipe. Rotate azimuth until a signal is reached.

### **4.2 Fine Tuning**

Peak the antenna signal by fine adjustments made in both azimuth and elevation.

Securely tighten the eight canister set screws.

Use the bottom hex nut of the elevation adjustment rod to slowly raise and lower the antenna until maximum signal is achieved.

Next, use the azimuth adjustment rod hex nuts to adjust left and right until maximum signal is achieved.

Repeat steps #2 and #3 until maximum signal is achieved.

Securely tighten all hardware used for adjustment.

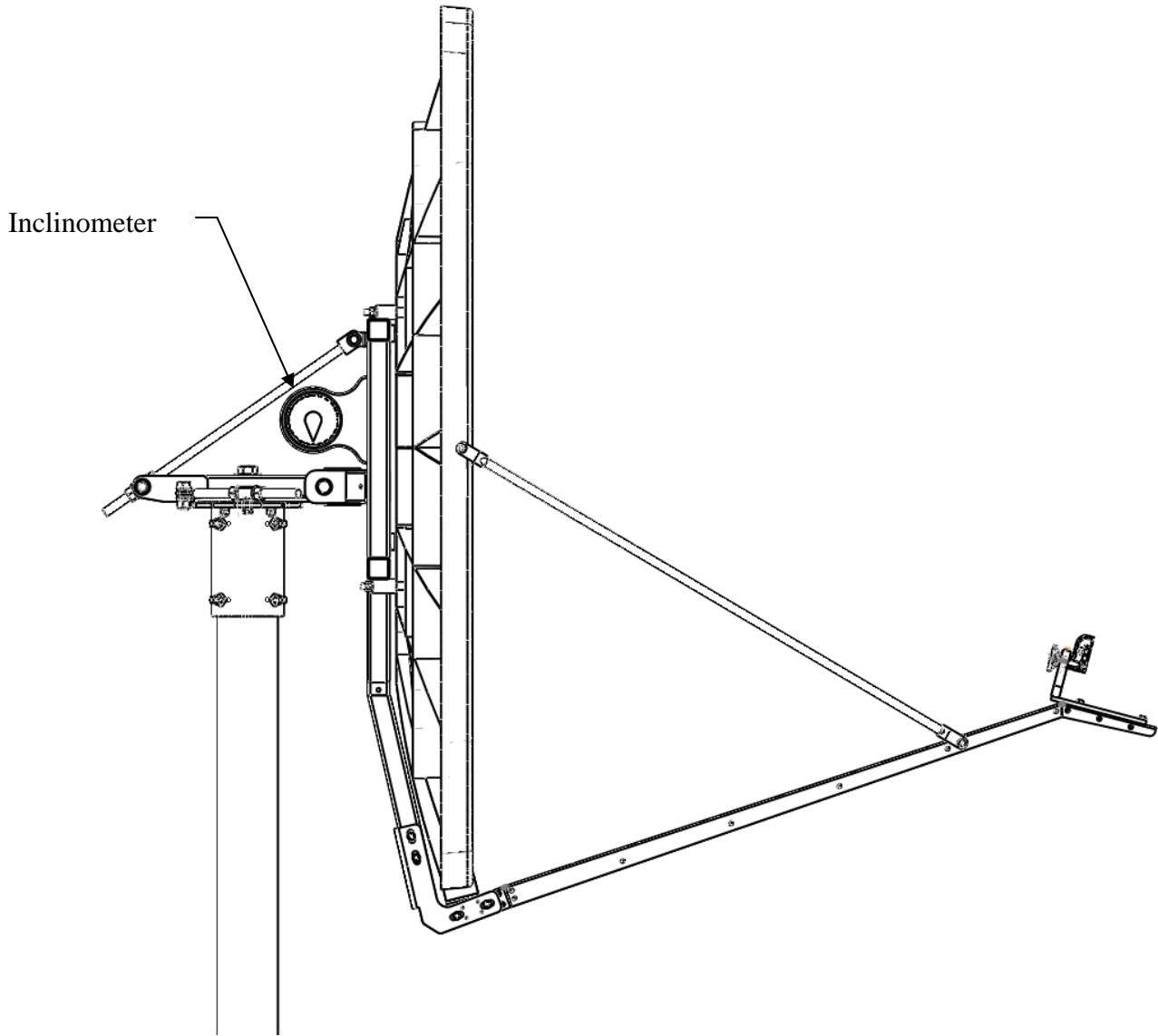

FIGURE 4.1

## **SECTION V**            **MAINTENANCE**

### **5.0**    **Maintenance Overview**

After installation, the antenna requires only periodic inspection. It is anticipated that maintenance, if required, will be minimal and easily handled by a local or in-house maintenance staff. The materials used in the construction of this Earth Station Antenna virtually eliminate any maintenance repairs.

### **5.1**    **Periodic Inspection**

It is suggested that a periodic inspection be performed at least every six months.

NOTE: After any very severe weather conditions, inspection of the antenna should be performed to determine if foreign objects have caused damage or if survival specifications have been exceeded.

This inspection should include the following:

- 1)    Check all bolting locations - all bolts should be tight.
- 2)    Check all structural members - repair or replace if damaged.
- 3)    Check the foundation anchor bolts - they must be secure and with no failure signs in foundation.
- 4)    Check for corrosion - on the reflector structure and mount.

### **5.2**    **Reflector**

General Dynamics' reflector does not require any maintenance. The composite construction of the reflector is virtually impervious to any damages that could be caused by weather or other atmospheric conditions.

It is only necessary to inspect for any physical damage done by vandalism or very severe weather conditions.

Should any damage be detected to a portion of the reflector, contact the Customer Service Department at General Dynamics for recommendations involving reflector repair.

### 5.3 **Mount And Reflector Support Structure**

The mount and reflector support structure supplied with this antenna is of steel construction and has a hot-dipped galvanized finish.

If inspection shows any signs of structural failure, the mount members that are damaged should be repaired or replaced.

Corrosion: Any corrosion on steel members may be repaired with a cold, zinc-rich galvanizing paint.

### 5.4 **Feed And Feed Support**

The feed support system should be inspected to insure that all hardware is secure. The feed/radio mounting bolts should be tight.

The feed horn window should be inspected to insure that it is intact so that no moisture can collect inside the feed horn. Replace if damaged.